



# QUIETFLO OWNER'S MANUAL

## INSTALLATION, OPERATION & PARTS

To prevent potential injury and to avoid unnecessary service calls, read this manual carefully and completely.

**CAUTION** - We highly recommend a qualified professional install and service this product.

**WARNING** - This manual contains important safety information that must be furnished to the end user of this product. **FAILURE TO READ AND FOLLOW ALL INSTRUCTIONS COULD RESULT IN SERIOUS INJURY.**

**SAVE THIS INSTRUCTION MANUAL**

624 South B Street \* Tustin, CA 92780  
Toll Free: 800.636.8866 \* Tel: 714.505.1166 \* Fax: 714.505.1160

[advantageman.com](http://advantageman.com)





**ADVANTAGE**  
MANUFACTURING

## PRODUCT REGISTRATION

(Retain for Your Records)

DATE OF INSTALLATION \_\_\_\_\_

INITIAL PRESSURE GAUGE READING (CLEAN FILTER) \_\_\_\_\_

PUMP MODEL \_\_\_\_\_ HORSEPOWER \_\_\_\_\_

FILTER MODEL \_\_\_\_\_

## IMPORTANT SAFETY INSTRUCTIONS

Before installing or servicing this electrical equipment, turn power supply OFF.

Basic safety precautions should always be followed, including the following: Failure to follow instructions may result in injury.



This is the safety-alert symbol. When you see this symbol on your pump manual, look for one of the following signal words and be alert to the potential for personal injury.



**WARNING** - Warns about hazards that could cause serious personal injury, death or major property damage and if ignored presents a potential hazard.

**CAUTION** - Warns about hazards that will cause or can cause minor or moderate personal injury and/or property damage and if ignored presents a potential hazard. It can also make consumers aware of actions that are unpredictable and unsafe.

The NOTICE label indicates special instructions that are important but not related to hazards.



### **WARNING**

Read and understand operator's manual and all other safety instructions before using this equipment.

**WARNING** - Read and follow all instructions in this owner's manual and on equipment. Failure to follow instructions can cause severe injury and/or death.

**NOTE:** When pump is mounted permanently within 5 ft. of the inside walls of a swimming pool, you must use a NO.8 AWG or larger conductor to connect to bonding conductor lug.

**WARNING** - To reduce the risk of injury, do not permit children to use this product unless they are closely supervised at all time.

**CAUTION** - For hot tubs and spa pumps, do not install within an outer enclosure or beneath the skirt of the hot tub or spa unless so marked.

# GENERAL INFORMATION

## WIRING

### WARNING: Risk of electrical shock or electrocution.



This pool pump must be installed by a licensed or certified electrician or qualified pool serviceman in accordance with the National Electrical Code and all applicable local codes and ordinances. Improper installation will create an electrical hazard which could result in death or damage property. Always disconnect power to the pool pump at the circuit breaker before servicing the pumo. Failure to do so could result in death or serious injury to serviceman, pool users or others due to electric shock.

1. Make sure all electrical breakers and switches are turned off before wiring motor.
2. Make sure that the wiring voltage matches the motor voltage (230v or 115v). If they do not match the motor will burn up.
3. Choose a wire size from Chart 1. When in doubt use a heavier gauge (larger diameter) wire. Heavier gauge will allow the motor to run cooler and more efficient.
4. Cut wires to the appropriate length so they don't overlap or touch when connected to the terminal board.
5. Make sure all electrical connections are clean and tight.
6. Permanently ground the motor using the internal, green ground terminal located on the inside of the motor canopy or access plate, see Figure 1. Use the correct wire size and type specified by the National Electrical Code. Make sure the ground wire is connected to an electrical service ground.

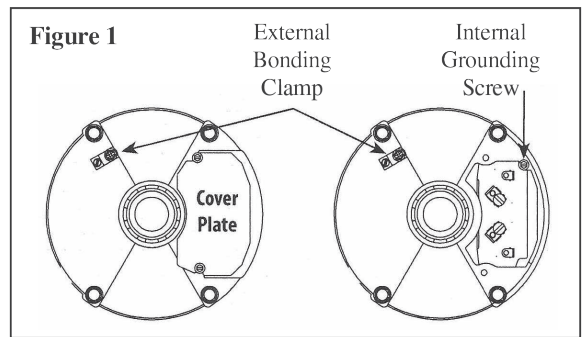

7. Bond the motor to the pool structure in accordance with the National Electrical Code. Use a solid NO. 8 AWG or larger copper conductor. Run a wire from the brass external bonding clamp, see Figure 1, to the pool bonding structure.

8. Connect the pump permanently to a circuit. Make sure no other lights or appliances are on the same circuit.

Chart 1

SUPPLY WIRE SIZES (AWG) Size and Length by Horsepower						
HP	115 Volts			230Volts		
	50 Ft.	100 Ft.	150 Ft.	50 Ft.	100 Ft.	150 Ft.
1/3	14	14	12	14	14	14
1/2	14	12	10	14	14	14
3/4	12	12	10	14	14	14
1	12	10	8	14	14	14
1-1/2	10	10	8	14	14	12
2	10	8	8	14	12	12
3	—	—	—	12	12	10

Wire Gauge Chart

Gauge	Inches	Equivalent in mm	Gauge	Inches	Equivalent in mm
8	0.16	4.06	27	0.0164	0.417
9	0.144	3.66	28	0.0148	0.376
10	0.128	3.25	29	0.0136	0.345
11	0.116	2.95	30	0.0124	0.315
12	0.104	2.64	31	0.0116	0.295
13	0.092	2.34	32	0.0108	0.274
14	0.08	2.03	33	0.01	0.254

**NOTE:** If the pump is installed below the water level of the pool, close return and suction lines prior to opening hair and lint pump. Make sure to re-open valves prior to operating.

# THE PUMP STRAINER BASKET

This unit, sometimes referred to as the “Hair and Lint Trap”, is the unit in front of the volute. Inside the chamber is the basket which must be kept clean of leaves and debris at all times. View basket through the “See Through Lid” to inspect for leaves and debris. Regardless of the length of time between filter cleaning, it is most important to visually inspect the hair and lint pot basket at least once a week. A dirty basket will reduce the efficiency of the filter, heater and also put an abnormal amount of stress on the pump motor which would result in a costly repair bill.

## MAINTENANCE

**WARNING: DO NOT** open the strainer pot if pump fails to prime or if pump has been operating without water in the strainer pot. Pumps operated in these circumstances may experience a build up of vapor pressure and may contain scalding hot water. Opening the pump may cause serious personal injury. In order to avoid the possibility of personal injury, make sure the suction and discharge valves are open and strainer pot temperature is cool to the touch, then with extreme caution only open the strainer pot.

**CAUTION:** To prevent damage to the pump and filter and for proper operation of the system, clean pump strain and skimmer baskets regularly.

## PUMP STRAINER BASKET CLEANING PROCEDURES

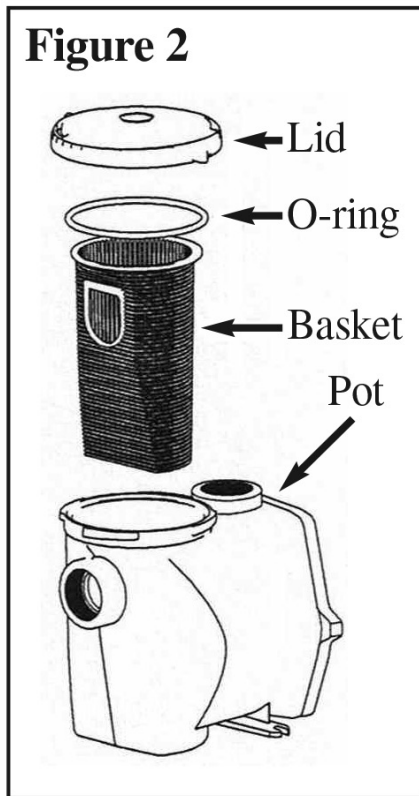

1. Turn both motor and power off at house circuit breaker.
2. Relieve pressure in the system.
3. Turn the Lid in a counter-clockwise direction until it stops.
4. Lift lid and remove basket.
5. Put the debris from the basket into the trash and rinse out the basket. If the basket is cracked, it should be replaced.
6. Replace the basket and fill the pump pot and volute up to the inlet port with water.
7. Clean the cover, O-ring and sealing surface of the pump pot. Grease the O-ring with Teflon or silicone lubricant.
8. Re-install the lid. See Figure 2.
  - a. Make sure the lid O-ring is properly placed. Seat the lid then turn clockwise until hand tight (Do not over tighten with tools). See Figure 3.
9. Turn the power “ON” at the house circuit breaker. Reset the pool time clock to the correct time.

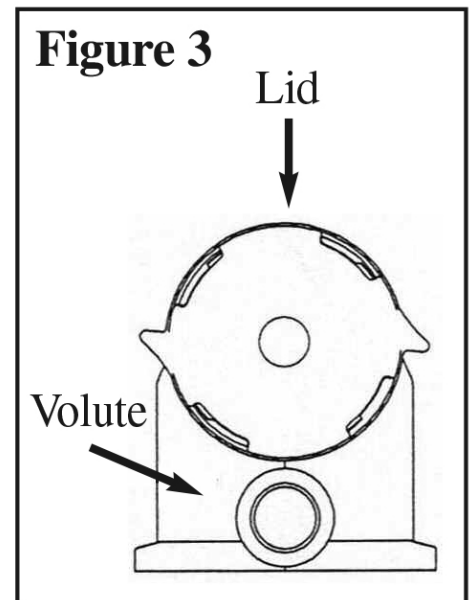



**WARNING:** THIS FILTER OPERATES UNDER HIGH PRESSURE. WHEN ANY PART OF THE CIRCULATION SYSTEM (e.g. LOCK RING, PUMP, FILTER, VALVES, ETC.) IS PRESSURIZED AIR CAN CAUSE THE LID TO BLOW OFF WHICH CAN RESULT IN SEVERE INJURY, DEATH, OR PROPERTY DAMAGE. TO AVOID THIS POTENTIAL HAZARD, FOLLOW THESE INSTRUCTIONS.



10. Open the manual air relief valve on top of the filter.
11. Stand clear of the filter. Start the pump.
12. Bleed air from the filter until a steady stream of water comes out. Close the manual air relief valve.

## WINTERIZING

1. If the air temperature drops below 35\* F the water in the pump can freeze and cause damage  
Freeze damage is NOT warrantable.
2. To prevent freeze damage follow the procedures listed below.
  - a. Shut off electrical power for the pump at the house circuit breaker.
  - b. Drain the water out of the pump case by removing the two drain plugs from the case. Store the plugs in the pump basket.
  - c. Cover the motor to protect it from severe rain, snow, and ice.
  - d. Do not wrap the motor in plastic. It will cause condensation and rust on the inside of the motor.

## CARE OF ELECTRIC MOTOR

1. Protect from heat.
  - a. Shade the motor from sun.
  - b. Any enclosure must be well ventilated to prevent overheating.
  - c. Provide ample cross ventilation.
2. Protect against dirt.
  - a. Protect from any foreign matter or splashing water.
  - b. Do not store (or spill) pool chemicals near motor.
  - c. Avoid sweeping or stirring up dust near motor while it is operating.
  - d. If a motor has been damaged by dirt it voids the warranty.
3. Protect against moisture.
  - a. Protect from splashing pool water.
  - b. Protect from the weather.
  - c. Protect from lawn sprinklers.



3. Protect against moisture. (CONTINUED)

- d. If a motor has become wet - let it dry before operating. Do not allow the pump to operate if it has been flooded.
- e. If a motor has been damaged by water it voids the motor warranty.

**NOTE: DO NOT** wrap motor with plastic or other air tight materials. The motor may be covered during a storm, for winter storage, etc., but never when in operation or expecting operation.

## SERVICE



### **WARNING: Risk of electrical shock or electricution.**



This Pool pump must be installed by a licensed or certified electrician or a qualified pool serviceman in accordance with the National Electrical Code and all applicable local codes and ordinances. Improper installation will create an electrical hazard which could result in death or damage to property. Always disconnect power to the pool pump at the circuit breaker before servicing the pump. Failure to do so could result in death or serious injury to serviceman, pool users or others due to electric shock.

**WARNING: DO NOT** open the strainer pot if pump fails to prime or if pump has been operating without water in the strainer pot. Pumps operated in these circumstances may experience a build up of vapor pressure and may contain scalding hot water. Opening the pump may cause serious personal injury. In order to avoid the possibility of personla injury, make sure the suction and discharge valves are open and strainer pot temperature is cool to the touch, then with extreme caution only open the strainer pot.

## PUMP DISASSEMBLY

1. All moving parts are located in the rear sub-assembly of this pump.

Tools required:

- a. 1/2 inch open end wrench.
- b. 9/16 inch open end wrench.
- c. Flat and Phillips head screwdrivers.

2. To remove and repair the motor sub-assembly perform the following procedures.

- a. Turn off the pump circuit breaker at the main panel.
- b. Drain the pump by removing the drain plugs.
- c. Remove the 6 bolts that hold the main pump body (strainer pot/volute) to the rear sub-assembly.
- d. GENTLY pull the two pump valves apart, removing the rear sub-assembly.
- e. Remove the diffuser.

**CAUTION:** Be sure not to scratch or mar the polished seal faces. Seal will leak if faces are damaged.

## PUMP DISASSEMBLY - (CONTINUED)

- f. Hold the impeller securely in place and remove the impeller lockscrew by using a Phillips head screwdriver. The screw is a left-handed thread and loosens in a clockwise direction.
- g. Remove the shaft cap located at the back of the motor and hold the shaft secure with a flat-head screwdriver (Century) or 7/16 inch open end wrench (Franklin).
- h. To unscrew the impeller from the shaft, twist the impeller counter clockwise.
- i. Remove the four bolts from the seal plate to the motor, using a 9/16 inch wrench.
- j. Place the seal plate face down on a flat surface and tap out the carbon/spring seal.
- k. Clean the seal plate, seal housing, and motor shaft.

## PUMP REASSEMBLY/SEAL REPLACEMENT - SEE FIGURE 4

1. When installing the replacement ceramic/ carbon seal, use silicone sealant on the metal portion, before pressing into the seal plate.
2. Before installing the ceramic section of the seal into the impeller, be sure the impeller is clean. Use a light density soap and water to clean the seal. Press the seal into the impeller with your thumbs and wipe off the ceramic and carbon faces with a clean cloth.
3. Remount the seal plate to the motor.
4. Screw the impeller onto the motor shaft.
5. Screw in the impeller lock screw (counter clockwise to tighten).
6. Remount the diffuser onto the seal plate.
7. Grease the O-ring with Teflon or Silicone lubricant.
8. Assemble the motor sub-assembly to the strainer pot-pump body. Do not tighten down any of the bolts until all 6 bolts are in place and finger tight.
9. Fill pump with water.
10. Reinstall the pump lid by turning clockwise until hand tight (Do not over tighten with tools).

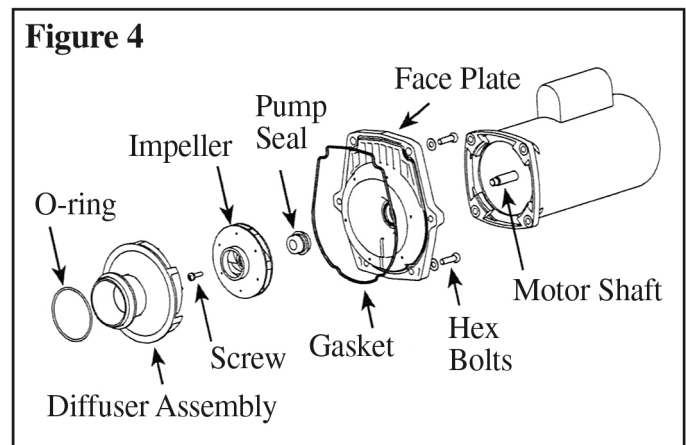

# PARTS LIST FOR QUIETFLO PUMP

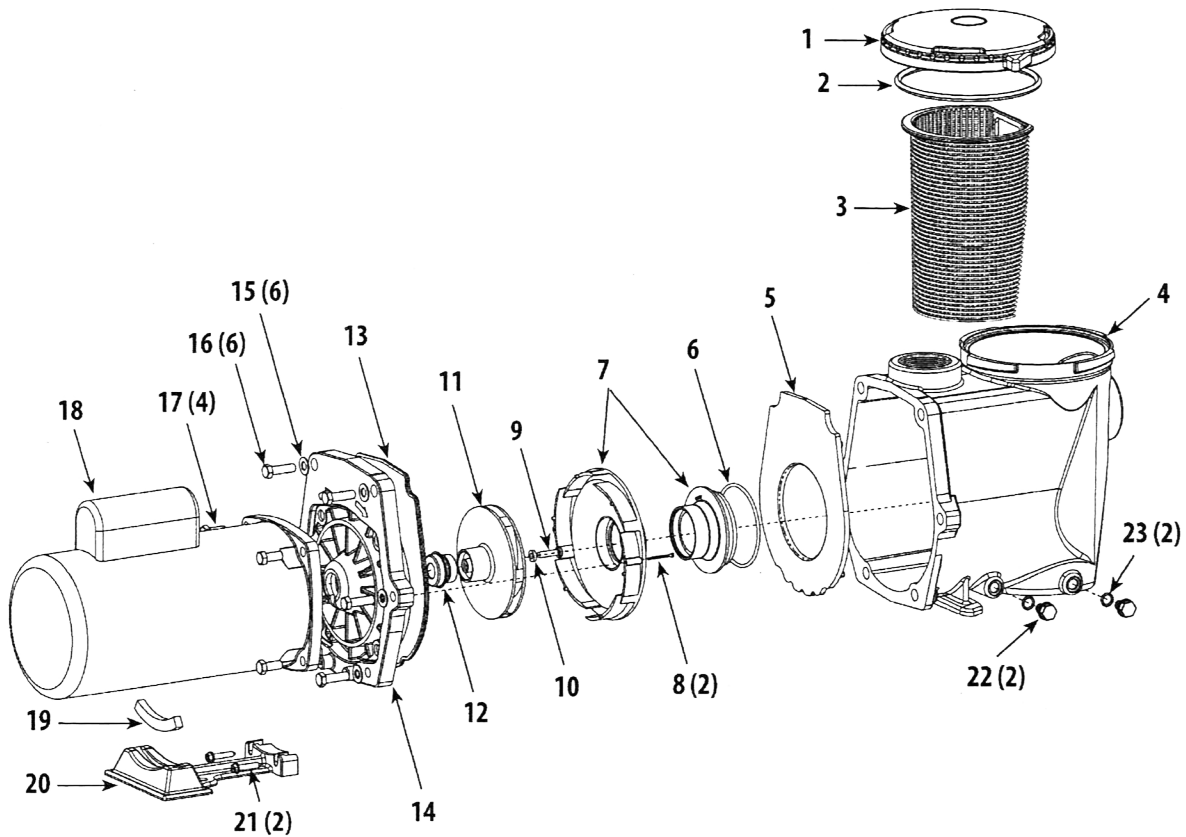

Item	Part No.	Part Description	Item	Part No.	Part Description
1	58921	Trap Lid	14	58939	Seal Plate
2	58922	Trap Lid O-Ring	15	58940	3/8" Washer
3	58923	Basket	16	58941	3/8" – 16 X 1 1/4" Bolt
4	58924	Pump Housing	17	58942	3/8" – 16 X 7/8"
5	58925	Diffuser Plate	18	58943 (1/2SQ)	Motor 1/2HP
6	58926	Diffuser O-Ring	18A	58944 (3/4SQ)	Motor 3/4HP
7	58927	Diffuser Assembly	18B	58945 (1SQ)	Motor 1HP
8	58928	Diffuser Bolt	18C	58946 (1.5SQ)	Motor 1.5HP
9	58929	Left Hand Screw	18D	58947 (2SQ)	Motor 2HP
10	58930	Gasket Left Hand Screw	18E	58948 (3SQ)	Motor 3HP
11	58931	Champion Impeller 1/2HP	19	58949	Motor Support Strip
11A	58932	Champion Impeller 3/4HP	20	58950	Motor Support Base
11B	58933	Champion Impeller 1HP	21	58951	Hex Screw 1/4" X 1 1/4"
11C	58934	Champion Impeller 1.5HP	22	58952	Drain Plug O-ring
11D	58935	Champion Impeller 2HP	23	58953	3/8" Drain Plug
11E	58936	Champion Impeller 3HP			
12	58937	Pump Seal Set			
13	58938	Seal Plate Gasket			



# 1 YEAR LIMITED WARRANTY

---

**CLAIMS:** All claims must be made within ten (10) calendar days after receipt of the merchandise. If any shipment is Here received in a damaged condition, your claim must be filed with the delivering carrier and noted on the freight bill before you accept the merchandise.

**RETURNS:** All returns are subject to our written approval and must be accompanied by a "Return Goods Authorization" number obtained from APP prior to shipment. Unauthorized returns will not be accepted. Freight must be prepaid. Material returned for credit, if in original condition and resalable, is subject to a 20% handling charge.

**TAXES:** Any Federal or State Excise or Sales Tax for which APP may be liable on any sale will be charged to and paid by the buyer. Buyer is responsible for furnishing a resale certificate.

**PRICES:** Prices and Products are subject to change without notice.

**LIMITED WARRANTY:** To Buyer, as original purchaser of the Goods, APP warrants its products free from defects

in materials and workmanship for a period of one year from the date of purchase. Parts which fail or become defective during the warranty period, except as a result of freezing, negligence, improper installation, use or care, shall be repaired or replaced, at our option, within ninety (90) calendar days of the receipt of the defective product, barring unforeseen delays. To obtain warranty, replacements or repair, defective components or parts should be returned, transportation paid, to the place of purchase. No returns may be made directly to the factory without the express written authorization of APP. Pump housing/strainers which become defective during the warranty period, except as a result of freezing, negligence, improper installation, use or care, or as the result of use in association with an automatic valving system, shall be repaired or replaced, at APP's option, without charge. All other conditions and terms of the standard warranty apply. APP shall not be responsible for cartage, removal and/or re installation labor or any other cost incurred in obtaining warranty replacements. The foregoing warranty does not apply to components manufactured by others. For such products, the warranty established by the respective manufacturers will apply.

**LIMITATION ON IMPLIED WARRANTIES:** Implied warranties, including any warranty or merchantability imposed on the sale of the goods under state law, are limited to one year duration for the goods or any parts.

**LIMITATIONS OF LIABILITY:** THE ESSENTIAL PURPOSE OF THIS PROVISION IS TO LIMIT APP'S LIABILITY HEREUNDER. EXCEPT FOR BODILY INJURY OR DEATH OF A PERSON, UNDER NO CIRCUMSTANCES WILL APP, ITS EMPLOYEES, OFFICERS OR DIRECTORS, AGENTS, SUCCESSORS OR ASSIGNS, BE LIABLE TO ANYONE UNDER ANY PRODUCT ORDER, SCHEDULE OR TERMS AND CONDITIONS HEREIN, UNDER ANY CONTRACT, STRICT LIABILITY, TORT (INCLUDING NEGLIGENCE) OR OTHER LEGAL OR EQUITABLE THEORY, WHETHER OR NOT FORESEEABLE OR FORESEEN, FOR: (1) BUSINESS INTERRUPTION COSTS, COST OF REWORK, RETESTING, PROCUREMENT OF SUBSTITUTE GOODS, REMOVAL AND RE INSTALLATION OF GOODS; OR (2) ANY SPECIAL, INCIDENTAL, EXEMPLARY, INDIRECT OR CONSEQUENTIAL DAMAGES, INCLUDING WITHOUT LIMITATION LOST PROFITS, LITIGATION COSTS, LOSS OF EQUIPMENT, PRODUCTION OR PROFIT, GOODWILL, LOSS OF REVENUE, OR LOSS OF UNITS; COST OF RENTING REPLACEMENTS, AND OTHER ADDITIONAL EXPENSES, EVEN IF THE AP HAS BEEN ADVISED OF THE POSSIBILITY OF SUCH DAMAGES, THERE IS A TOTAL AND FUND A MENTAL

**BREACH OF THIS AGREEMENT OR WHETHER ANY REMEDY PROVIDED.**

**HEREIN FAILS OF ITS ESSENTIAL PURPOSE. APP'S LIABILITY AND BUYER'S SOLE REMEDY, WHETHER IN CONTRACT, UNDER WARRANTY, IN TORT (INCLUDING NEGLIGENCE,) IN STRICT LIABILITY OR OTHERWISE, SHALL NOT EXCEED THE RETURN OF THE AMOUNT OF THE PURCHASE PRICE PAID BY BUYER AND SHIPMENT COSTS.**

**INDEMNIFICATION:** Buyer will defend and indemnify APP and its directors, employees, agents, customers, end users, successors and assigns from and against all actual and alleged claims, liabilities, suits, damages, losses and expenses (including attorney's fees and legal costs) arising from, or caused in whole or in part, by buyers breach of any provision, term or condition of purchase.

**BINDING EFFECT:** All sales transactions are binding on APP and the buyer and their respective directors, officers, employees, agents, subcontractors, successors and permitted assigns.

**GOVERNING LAW:** All transactions will be interpreted and enforced under the laws of the State of California (including without limitation the Uniform Commercial Code as adopted by the California), without recourse to the conflict of laws provision thereof. In no event will the provisions of the UN Convention of the International Sale of Goods apply to any purchases. APP and buyer agree that any action or proceeding arising out of or in connection with any sale of product or service, will be brought exclusively to a court of competent jurisdiction in the County of Orange, State of California.

**THE LIMIT OF LIABILITY FOR ANY CLAIMS SHALL NOT EXCEED THE AMOUNT PAID OR PREPAID ON ACCOUNT BY BUYER FOR THE GOODS GIVING RISE TO SUCH CLAIMS. BUYER SHALL BE DEEMED TO ASSUME ALL LIABILITY FOR ANY AND ALL DAMAGES ARISING FROM OR IN CONNECTION WITH THE USE OR MISUSE OF THE GOODS BY BUYER, ITS EMPLOYEES, CUSTOMERS AND OTHERS. SELLER SHALL NOT BE LIABLE FOR AND BUYER AGREES TO INDEMNIFY, DEFEND AND HOLD SELLER HARMLESS FROM ANY CLAIMS BASED ON SELLER'S COMPLIANCE WITH BUYER'S DESIGNS, SPECIFICATIONS OR INSTRUCTIONS, OR MODIFICATION OF ANY GOODS BY PARTIES OTHER THAN SELLER, OR USE IN COMBINATION WITH OTHER PRODUCTS. EACH PARTY RECOGNIZES AND AGREES THAT THE WARRANTY DISCLAIMERS AND LIABILITY AND REMEDY LIMITATIONS HEREIN ARE MATERIAL, BARGAINED FOR BASES OF ANY ORDER OR CONTRACT AND THAT THEY HAVE BEEN TAKEN INTO ACCOUNT AND REFLECTED IN DETERMINING THE CONSIDERATION TO BE GIVEN BY EACH PARTY UNDER ANY ORDER OR CONTRACT AND IN THE DECISION BY EACH PARTY TO ENTER INTO SUCH ORDER OR CONTRACT.**

Copyright Notices: Polaris® is a registered trademark of Zodiac Pool Care, Inc., Letro® is a registered trademark of Letro Products, Sta-Rite® is a registered trademark of Sta-rite Industries, Hayward® is a registered trademark of Hayward Manufacturing Co., Inc., WhisperFlo® is a registered trademark of Pentair Pool and Spa, Inc., Noryl is a registered trademark of GE Plastics, Northstar™ is a trademark of Hayward Manufacturing Co., Inc., Cal Spas® is a registered trademark of California Acrylic Industries, Inc., Aquaflo® is the registered trademark of LSP Products Group, Inc., Vico® is a registered trademark of Vico Industries, Waterway® is a registered trademark of Waterway Plastics, Advantage Manufacturing™ is trademark of Advantage Manufacturing, Federal Copyright – Advantage Manufacturing ©2007.